



PRODUCTS CATALOG

ELECTRICAL ENCLOSURES & MODULAR CABINETS



20

exmweb.com

NEMA 4-12 ENCLOSURES

5412 ESTH

WATER, OIL & DUST TIGHT INSULATED ENCLOSURES (WELDED FEET)

The 5412 ESTH insulated enclosures are used indoors or outdoors in areas where the enclosures may be subject to hosing or water coming from any direction, or for protection against dust, dirt or oil splashing. The 5412 ESTH are made of high quality 14 GA or 16 GA steel, with continuously welded corner seams. **One layer of 0.75" foil faced R5 insulation, is installed over the inner surface of the enclosures body and door.** The opening has a curled lip around all sides to

increase rigidity and prevent dripping water from entering the enclosure when the door is open. A high quality, robotically poured-in-place, seamless gasket ensures a complete and durable water tight seal. The pins of the concealed hinges can be pulled out to remove the door. A ¼ turn locking mechanism ensures positive closing. External mounting feet are provided. **Each enclosure comes complete with a 12 GA galvanized inner panel,** which is double bent* for maxi-

imum rigidity and mounts on M8 welded studs. Enclosures are finished with heat fused powder paint, electrostatically applied on a pretreated base. Box is ANSI/ASA 61 smooth gray.

**CSA Certified / UL Listed
NEMA/EEMAC 4-12 / IP66**

Refer to p.734 to validate choice of substrate for the application

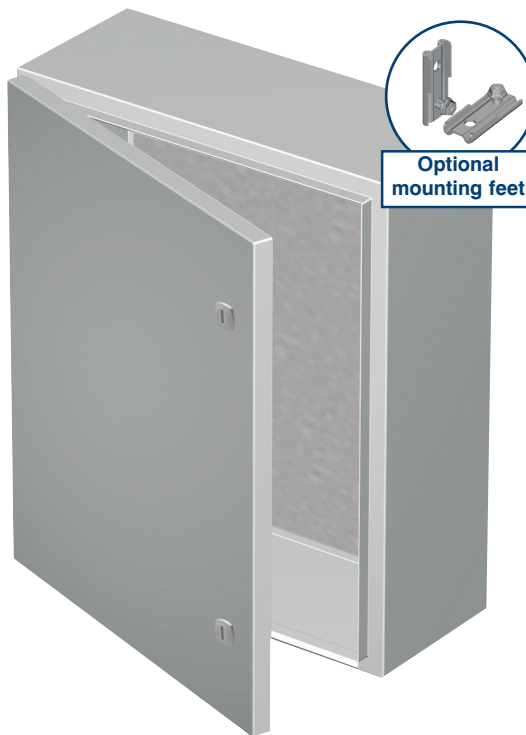
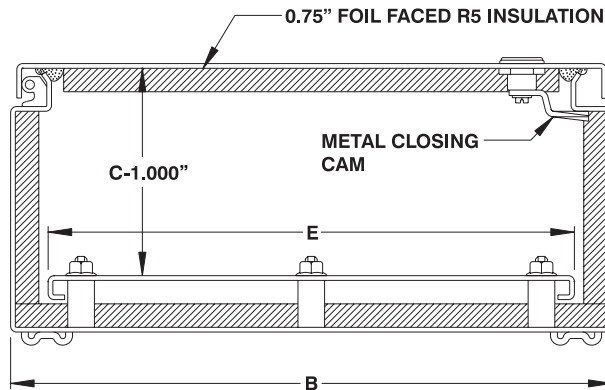

CATALOG NUMBER	DIMENSIONS					SHIP WGT LBS.
	A	B	C	D	E	
5412 ESTH121206	12	12	6	10	10	19
5412 ESTH122406	12	24	6	10	22	35
5412 ESTH161206	16	12	6	14	10	24
5412 ESTH161606	16	16	6	14	14	31
5412 ESTH162006	16	20	6	14	18	37
5412 ESTH201206	20	12	6	18	10	29
5412 ESTH201606	20	16	6	18	14	37
5412 ESTH202006	20	20	6	18	18	45
5412 ESTH202406	20	24	6	18	22	53
5412 ESTH241206	24	12	6	22	10	35
5412 ESTH241606	24	16	6	22	14	44
5412 ESTH242006	24	20	6	22	18	53
5412 ESTH242406	24	24	6	22	22	62
5412 ESTH301606	30	16	6	28	14	53
5412 ESTH302006	30	20	6	28	18	65
5412 ESTH302406	30	24	6	28	22	76
5412 ESTH362406	36	24	6	34	22	90
5412 ESTH363006	36	30	6	34	28	109
5412 ESTH122408	12	24	8	10	22	38
5412 ESTH161208	16	12	8	14	10	27
5412 ESTH161608	16	16	8	14	14	34
5412 ESTH162008	16	20	8	14	18	41
5412 ESTH201208	20	12	8	18	10	33
5412 ESTH201608	20	16	8	18	14	41
5412 ESTH202008	20	20	8	18	18	49
5412 ESTH202408	20	24	8	18	22	57
5412 ESTH241208	24	12	8	22	10	38
5412 ESTH241608	24	16	8	22	14	48
5412 ESTH242008	24	20	8	22	18	57
5412 ESTH242408	24	24	8	22	22	67
5412 ESTH243008	24	30	8	22	28	81
5412 ESTH301208	30	12	8	28	10	46
5412 ESTH301608	30	16	8	28	14	58
5412 ESTH302008	30	20	8	28	18	70
5412 ESTH302408	30	24	8	28	22	81
5412 ESTH303008	30	30	8	28	28	98
5412 ESTH303608	30	36	8	28	34	116
5412 ESTH362408	36	24	8	34	22	95
5412 ESTH363008	36	30	8	34	28	116
5412 ESTH363608	36	36	8	34	34	136
5412 ESTH422408	42	24	8	40	22	110
5412 ESTH423008	42	30	8	40	28	133



WATER, OIL & DUST TIGHT INSULATED ENCLOSURES (WELDED FEET)

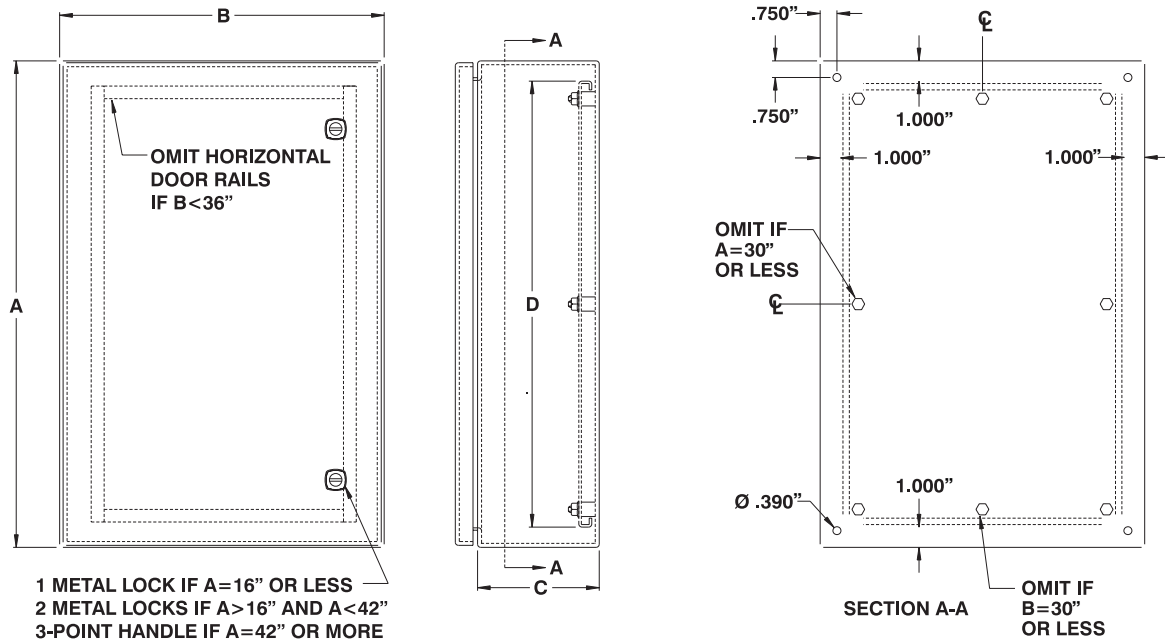

CATALOG NUMBER	DIMENSIONS					SHIP WGT LBS.	CATALOG NUMBER	DIMENSIONS					SHIP WGT LBS.
	A	B	C	D	E			A	B	C	D	E	
5412 ESTH423608	42	36	8	40	34	156	5412 ESTH363012	36	30	12	34	28	129
5412 ESTH482408	48	24	8	46	22	124	5412 ESTH363612	36	36	12	34	34	150
5412 ESTH483008	48	30	8	46	28	150	5412 ESTH422412	42	24	12	40	22	118
5412 ESTH483608	48	36	8	46	34	177	5412 ESTH423012	42	30	12	40	28	147
5412 ESTH603608	60	36	8	58	34	218	5412 ESTH423612	42	36	12	40	34	172
5412 ESTH161210	16	12	10	14	10	30	5412 ESTH482412	48	24	12	46	22	138
5412 ESTH201610	20	16	10	18	14	44	5412 ESTH483612	48	36	12	46	34	193
5412 ESTH202010	20	20	10	18	18	53	5412 ESTH602412	60	24	12	58	22	169
5412 ESTH241210	24	12	10	22	10	42	5412 ESTH603612	60	36	12	58	34	236
5412 ESTH242010	24	20	10	22	18	62	5412 ESTH723012	72	30	12	70	28	240
5412 ESTH242410	24	24	10	22	22	71	5412 ESTH723612	72	36	12	70	34	279
5412 ESTH302010	30	20	10	28	18	74	5412 ESTH242016	24	20	16	22	18	74
5412 ESTH302410	30	24	10	28	22	86	5412 ESTH242416	24	24	16	22	22	86
5412 ESTH362410	36	24	10	34	22	101	5412 ESTH302416	30	24	16	28	22	102
5412 ESTH363010	36	30	10	34	28	122	5412 ESTH362416	36	24	16	34	22	119
5412 ESTH423010	42	30	10	40	28	140	5412 ESTH363016	36	30	16	34	28	142
5412 ESTH423610	42	36	10	40	34	164	5412 ESTH423616	42	36	16	40	34	187
5412 ESTH483010	48	30	10	46	28	158	5412 ESTH483616	48	36	16	46	34	210
5412 ESTH483610	48	36	10	46	34	185	5412 ESTH603616	60	36	16	58	14	255
5412 ESTH603610	60	36	10	58	34	227	5412 ESTH723016	72	30	16	70	28	260
5412 ESTH201612	20	16	12	18	14	48	5412 ESTH723616	72	36	16	70	34	301
5412 ESTH202012	20	20	12	18	18	57	5412 ESTH302420	30	24	20	28	22	113
5412 ESTH202412	20	24	12	18	22	66	5412 ESTH363020	36	30	20	34	28	155
5412 ESTH242012	24	20	12	22	18	66	5412 ESTH483620	48	36	20	46	34	226
5412 ESTH242412	24	24	12	22	22	76	5412 ESTH603620	60	36	20	58	34	274
5412 ESTH302412	30	24	12	28	22	92	5412 ESTH723020	72	30	20	70	28	280
5412 ESTH303012	30	30	12	28	28	110	5412 ESTH302424	30	24	24	28	22	123
5412 ESTH362412	36	24	12	34	22	107	5412 ESTH723024	72	30	24	70	28	300

* Only panels with sides 20" or more are double bent.

CUSTOMIZE THIS
ENCLOSURE WITH **BOXCAD**
SIZE - COLOR - CUT-OUTS

